



Precise.

Quality.

Reliable.



Table of Contents

Overview

Features and Benefits	2
Operation of Snap-Action	3
Operation of Modulating	4
Standard Features and Options	5
Valve Exploded Views	6
Snap Cutaway View	7
Modulator Cutaway View	8
Inlet Flange Ratings	9
Orifice Dimensions	11
Model Numbering System	12
How to Size a Valve	13

About Us

Mr. Julian Taylor started Taylor Valve Technology (originally Taylor Oil Tools) in 1958 when a Texaco® supervisor approached him regarding a problem with hunters targeting and shooting pressure gauges on oil wells. In response, Mr. Taylor invented the Gauge Plug® and Gauge Probe® fittings, which are still used to this day.

Taylor Valve Technology has continued to expand and grow with the company's primary objective being solving customer problems. As a result, Taylor Valve Technology products are recognized and distributed worldwide.

Pilot Operated Features and Benefits

Taylor Valve Technology's Series 9300 Snap Acting Safety Valve with the non-flowing pilot provides highly reliable system overpressure protection.

This valve can be used for air, gas, vapor, and most mixed phase services. The 9300 is available with effective orifice areas of 0.128 through 45.664 inch, valve inlet sizes 1-inch through 8-inch, set pressures from 15 to 3705 psig (1 to 260 barg). Continuous service temperatures from -50°F to +450°F.

Features and Benefits

Easily Adjusted. Adjustable set pressure is accurate and dependable. Adjustable blowdown is external, which reduces time and cost consuming expenditures of valve removal. System downtime is also greatly reduced.

Maintenance Cost Is Cut. With a replaceable soft seat, expensive parts and time consuming lapping of metal seats are no longer necessary.

ASME Section VIII Code Stamp. Used for air, gas and vapor service, the capacity is assured by an independent third party, the ASME National Board Laboratory in Columbus, Ohio.

Increased Output of System. The valve can be set within 5% of system operating pressure allowing the process to be maintained at close tolerance without valve leakage. This results in greater process system output.

Dirty Service. The pilot is a non-flowing design which minimizes the entry of dirt and accumulation of hydrates. Most of the contaminants will be removed in the coalescing filter upstream of the pilot. The cartridge type filter is standard on all Taylor Pilots and finishes the gas before it enters the pilot cavity.

Pilot is Mounted Vertically. Consistent set pressure and blowdown is assured compared to horizontally mounted pilots which are erratic.

• **Orifice Nozzles.** The orifice size may be changed by replacing a single component. There are multiple orifice sizes for each nominal body size.

• **Built-in Field Test Port.** Provides the ability to accurately verify the set pressure with the valve in place and in service.

• **Durable, Rugged Mounting of Pilot.** Extra rigid mounting against the body protects the pilot from system vibration.

Standard Features

- (1) Proven superior main seat (not a trapped "O" ring).
- (2) Shuttle spool valve to select system pressure or test pressure. Sealed at all times.
- (3) Secondary 40 micron filter to filter test port fluids and system fluids (no tape dope can clog the pilot).
- (4) Internal Back Flow Preventer senses the downstream pressure and balances out the effects on set pressure. Therefore, set pressure is not effected by varying downstream pressure.

Operation of a Snap-Acting Pilot-Operated Relief Valve

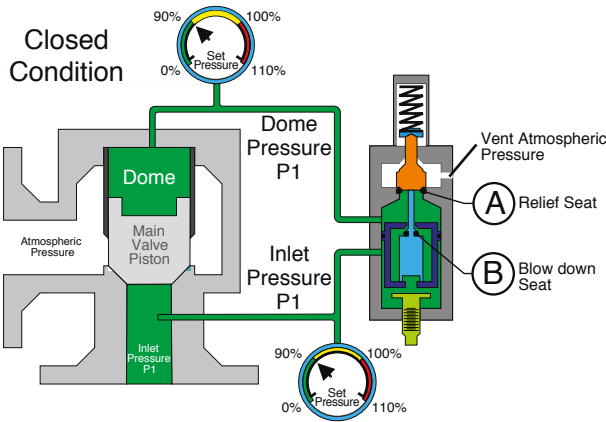

SYSTEM PRESSURE < SET PRESSURE

System is at an operating pressure condition. The seat (B) feeding the dome is open. The seat (A) feeding the vent is closed, the dome is pressurized and the main valve piston is on seat. The valve is in the operational mode closed position.

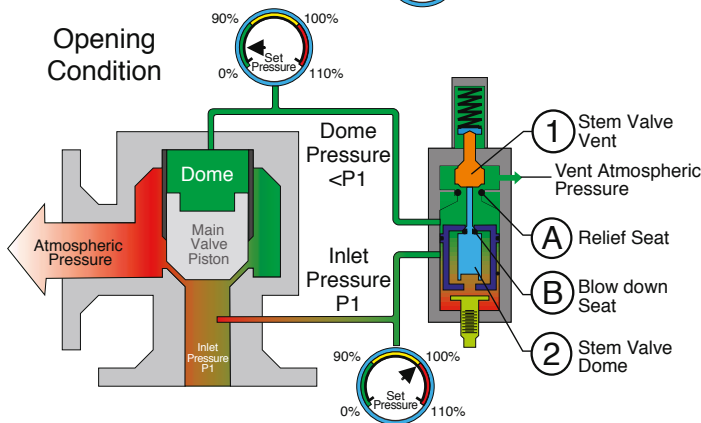

SYSTEM PRESSURE = SET PRESSURE

System pressure reaches set point. The valve stem (1) opens the vent seat (A) and releases pressure off the dome to atmosphere. The valve stem (2) is pushed on seat (B) by the system pressure, isolating system pressure from the dome and the main valve piston begins to open.

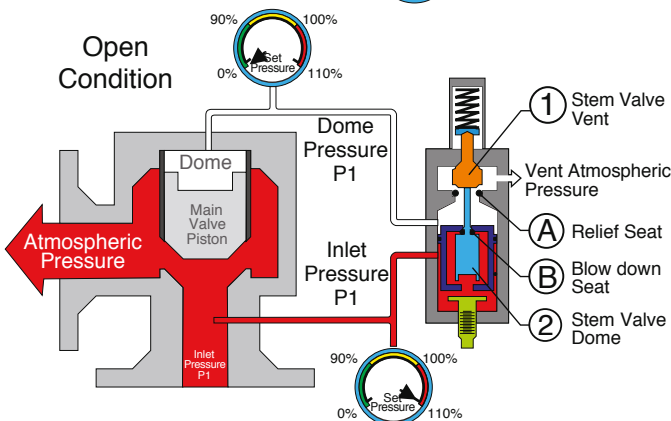

SYSTEM PRESSURE > SET PRESSURE

The valve stem (1) and seat (A) remain open and the dome is at atmospheric pressure. The valve stem (2) remains closed on seat (B) and the main valve piston is open. System pressure is relieving through main body.

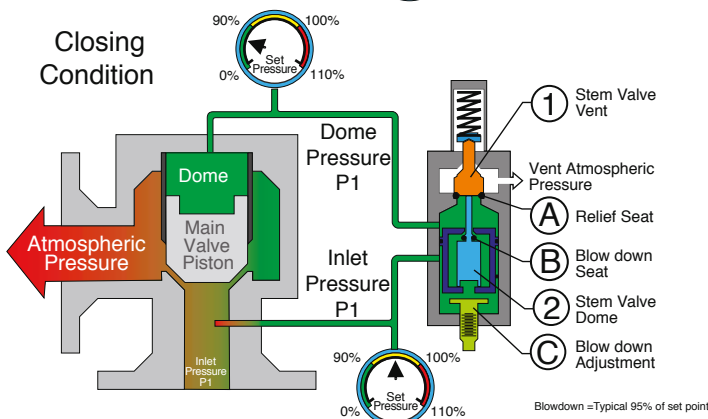

SYSTEM PRESSURE 95% OF SET PRESSURE

The system pressure is reduced to 95% of the set pressure, Blowdown is set at 5% by adjusting valve (C). Stem (1) closes seat (A) sealing the dome from atmospheric pressure. The valve stem (2) moves to the open position and system pressure begins to pressurize the dome, forcing the main valve piston to go back on seat and closing the relief valve.

Operation of a Modulating Pilot-Operated Relief Valve

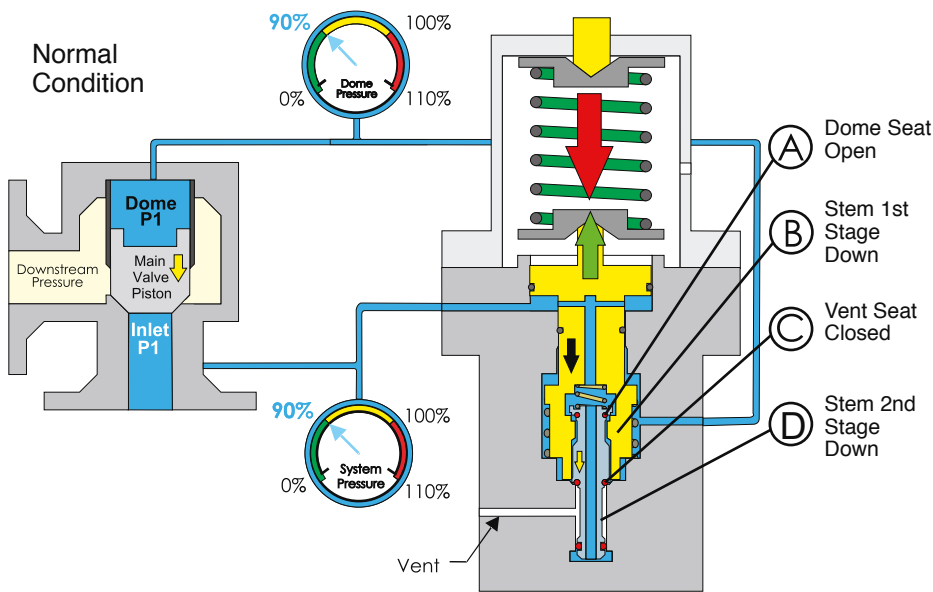

SYSTEM PRESSURE < SET PRESSURE

System is operating within a normal pressure condition. Seat (A) feeding the dome is open and Seat (C) feeding the vent is closed. The dome is pressurized with system pressure and the main valve piston is on seat. The valve is in full operational mode. The two stage stem is in the full down position.

SYSTEM PRESSURE = SET PRESSURE

As system pressure increases and reaches set point the first stage piston moves upward and closes the dome seat. Main valve dome pressure is now sealed, because the vent seat is also sealed. A further increase in system pressure opens the vent seat allowing a controlled release of the dome pressure. The reduced dome pressure decreases lift on the first stage piston reseating dome vent and locking in dome pressure so there is no pilot flow. The first and second stage pistons will move in response to changes in system and dome pressures. This action will allow the main valve piston to lift and maintain flow stabilizing the process system. Full lift and full capacity are gained with little additional overpressure.

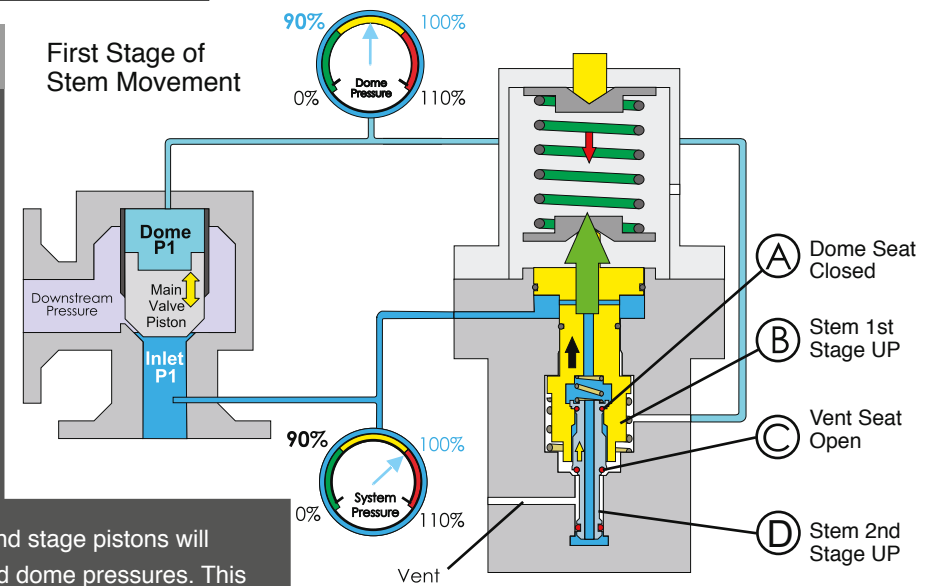

SYSTEM PRESSURE > SET PRESSURE

System is in an upset condition and at a 10% overpressure. Seat (A) feeding the dome is closed and Seat (B) feeding the vent is open. The dome is depressurized, the first and second stage of the stem are fully up and the main valve piston is in full lift. The valve is now operating at full capacity.

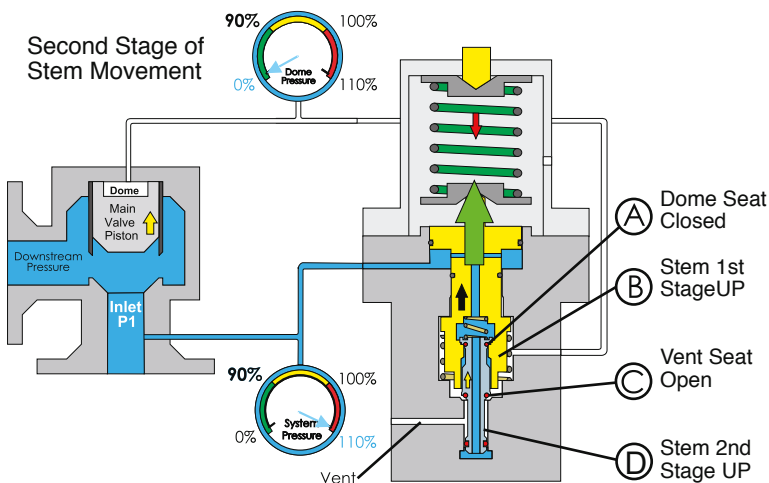

Standard Features and Options

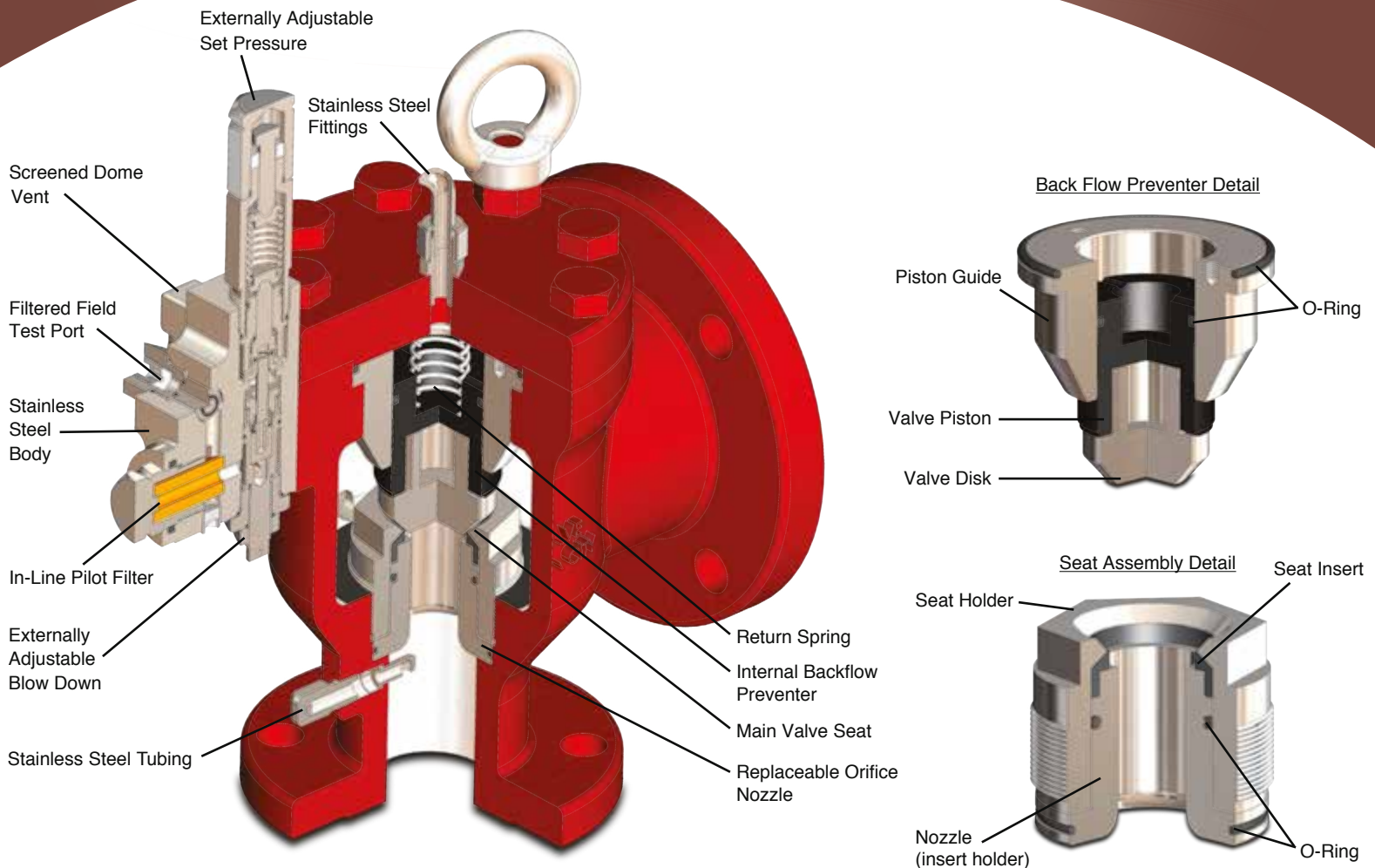

1. Manual Unloader

When the Manual unloader is open it vents the dome faster than it can be resupplied by the system pressure, causing the main valve to open.

2. Remote Unloader

The remote unloader, an electrically or pneumatically operated three-way valve which, when opened, vents the dome pressure faster than it can be supplied by the pilot source. This reduces the dome pressure and opens the main valve.

3. Remote Valve Lift Indicator

A differential Pressure switch is mounted between the pressure sensing line and the dome. Valve open conditions is indicated when the dome pressure is lower than the system pressure.

4. Remote Pressure Sensing

The pilot senses the pressure directly from the protected vessel.

5. Lift Lever on Pilot

For compressed air service and vapor application.

6. Pilot Vent Connected to the Main Valve Outlet

7. Switched Dual Pilots

Dual pilots allow for continuous service when maintenance is required on one pilot without compromising safety, system or production. The gauged 4-way valves insure the "out of service" pilot is depressurized and can be safely maintained.

8. Dual Outlets

4,6, and 8

Exploded View

API Main Valve

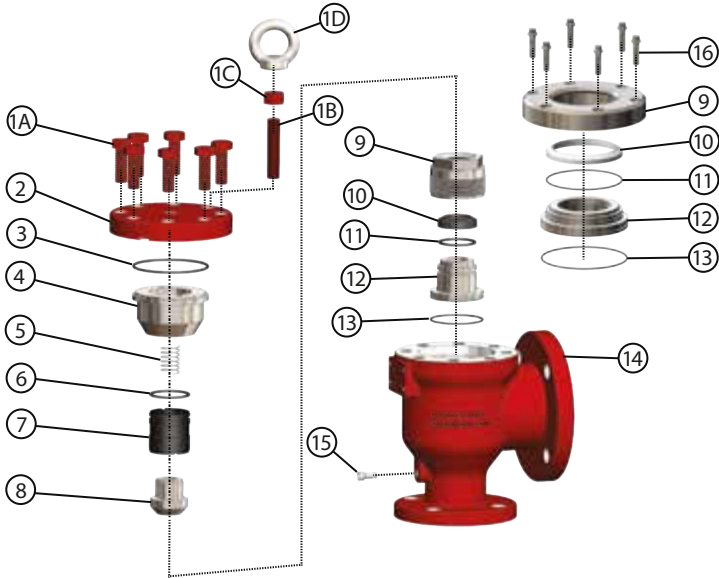

Full Bore Main Valve

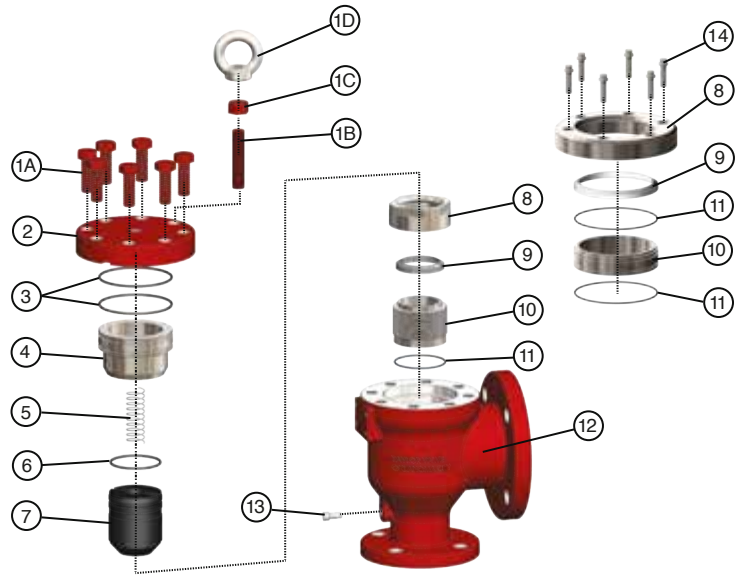

Part#	Qty	Description	Standard Materials	Optional Materials
1		Bonnet Bolting		
1A	Vary by size	Bolts	SA193 B7	
1B	Vary by size	Studs	SA193 B7	
1C	Vary by size	Nuts	SA193 2H	
1D	Vary by size	Eye Nuts	Zinc Plated CS	
2	1	Valve Bonnet	SA105	316SS
3	1	O-Ring	FKM	++
4	1	Piston Guide	17-4PH SS H1150	316SS
5	1	Return Spring	316SS	
6	1	O-Ring	FKM	++
7	1	Valve Piston	316SS	
8	1	Valve Disc	17-4PH SS H1150	316SS
9	1	Seat Holder	17-4PH SS H1150	316SS
10	1	Seat Insert	PTFE/FKM	++
11	1	O-Ring	FKM	++
12	1	Insert Holder/Nozzle	316SS	
13	1	O-Ring	FKM	++
14	1	Valve Body	SA216 WCC	SA351 CF8M
15	1	Pilot Tube	316SS	
16	Vary by size	Seat Holder Bolts	Carbon Steel	
17*	1	Data Label	304SS	
18*	2	Drive Screws	18-8SS	

Part#	Qty	Description	Standard Materials	Optional Materials
1		Bonnet Bolting		
1A	Vary by size	Bolts	SA193 B7	
1B	Vary by size	Studs	SA193 B7	
1C	Vary by size	Nuts	SA193 2H	
1D	Vary by size	Eye Nuts	Zinc Plated CS	
2	1	Valve Bonnet	SA105	316SS
3	2	O-Ring	FKM	++
4	1	Piston Guide	17-4PH SS H1150	316SS
5	1	Return Spring	316SS	
6	1	O-Ring	FKM	++
7	1	Valve Piston	316SS	
8	1	Seat Holder	17-4PH SS H1150	316SS
9	1	Seat Insert	PTFE/FKM	++
10	1	Insert Holder/Nozzle	316SS	
11	Vary by size	O-Ring	FKM	++
12	1	Valve Body	SA216 WCC	SA351 CF8M
13	1	Pitot Tube	316SS	
14	Vary by size	Seat Holder Bolts	Carbon Steel	
15*	1	Data Label	304SS	
16*	2	Drive Screws	18-8SS	

* Not Shown ++Based on Application
Note: All bolting Zinc Phosphate Coated unless otherwise stated

* Not Shown ++Based on Application
Note: All bolting Zinc Phosphate Coated unless otherwise stated

NOTE: Taylor Valve reserves the right to change product designs and specifications without notice.

Snap Cutaway View

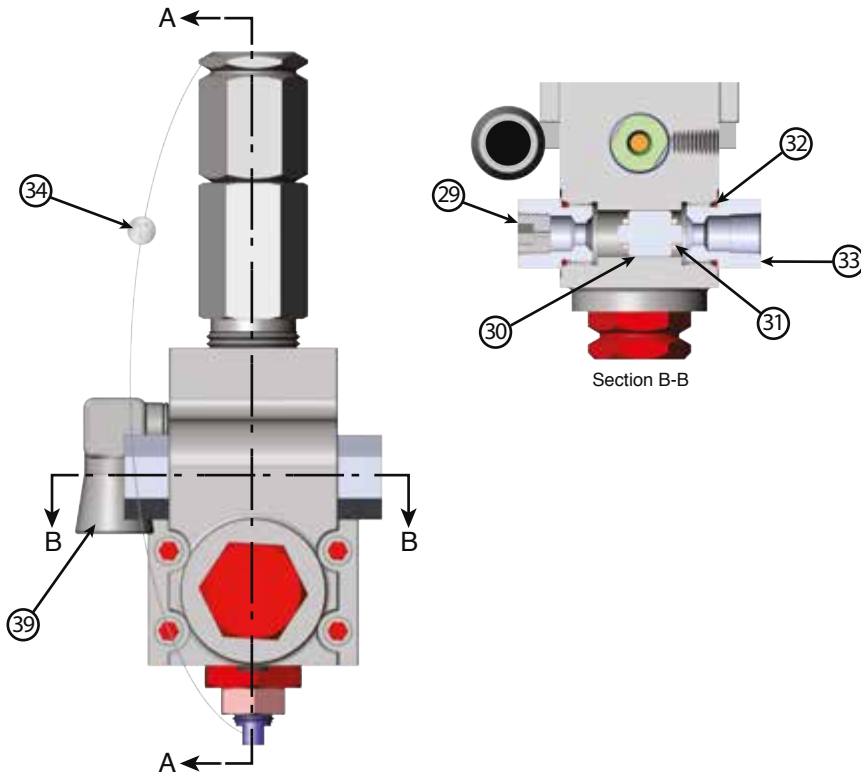
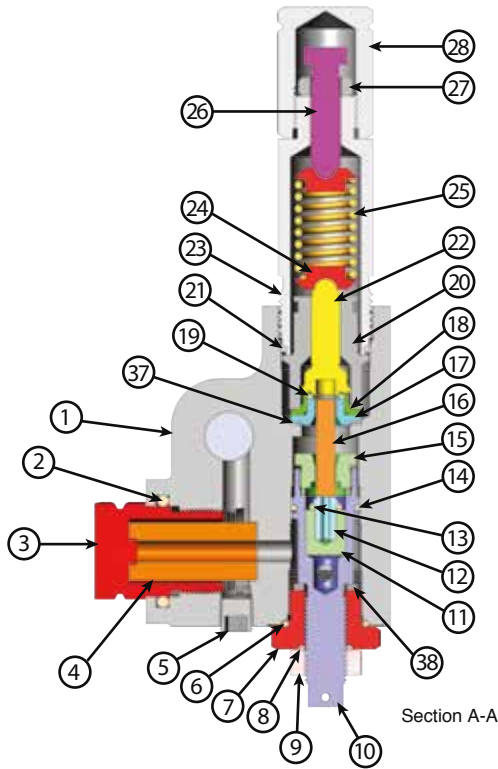

Part #	Qty	Description	Materials
1	1	Body	SA351 CF8M
2	1	O-Ring 2-215	FKM**
3	1	Filter Cap	316SS
4	1	40 Micron Filter	-
5	1	Pipe Plug 1/8 NPT	316SS
6	1	O-Ring 2-020	FKM**
7	1	Seat Adjustment Bushing	316SS
8	1	O Ring 2-014	FKM**
9	1	Jam Nut	304SS
10	1	Blowdown Adjust. Housing	316SS
11	1	Reseat Piston	316SS
12	1	Seat Retainer	316SS
13	1	O-Ring 2-010	FKM**
14	1	O-Ring 2-017	FKM**
15	1	Seat	316SS
16	1	Push Rod	316SS
17	1	Rod Guide	316SS
18	1	Guide Retainer	316SS
19	1	O-Ring 2-011	FKM**
20	1	Spindle Guide	316SS
21	1	O-Ring 2-021	FKM**
22	1	Spindle	316SS
23	1	Spring Housing	316SS
24	2	Spring Keeper	316SS
25	1	Spring	17-7SS
26	1	Adjustment Screw	316SS
27	1	Jam Nut	304SS
28	1	Cap	316SS
29	1	Pipe Plug 1/4 NPT	316SS
30	1	Shuttle Valve	316SS
31	2	O-Ring 2-010	FKM**
32	2	O-Ring 2-114	FKM**
33	2	Shuttle Valve Nut	316SS
34	1	Lead Seal Wire	3 Ply SS
35*	1	Tube Fitting	316
36*	1	Male Connect Tube Fitting	316
37	1	Washer	PTFE
38	3	Shims	304SS
39	1	3/8 Street Elbow	316
40*	2	Drive Screws	18-8SS
41*	1	Label	316SS

*Items not shown
 **Dependent on application

Modulator Cutaway View

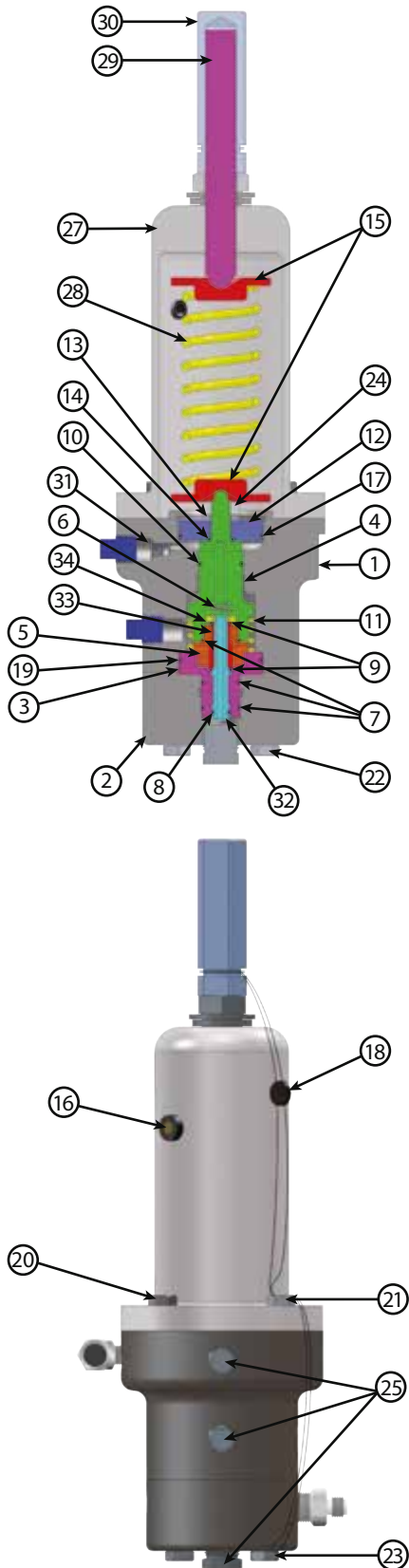

Part #	Qty	Description	Materials
1	1	Body	316SS**
2	1	Body Bottom	316SS**
3	1	Outlet Nozzle	316SS**
4	1	Feedback Piston	316SS**
5	1	Inlet Nozzle	316SS**
6	1	Spool Spring	INCONEL X-750
7	3	Nozzle Seals	FKM**
8	1	Lower Spool Seal	FKM**
9	2	Med. Spool Seals	FKM**
10	1	Feedback Piston Seal	FKM**
11	1	Bias Spring	INCONEL X-750
12	1	Sense Piston	316SS**
13	1	Lock Washer	18-8SS
14	1	Upper Piston Seal	FKM**
15	2	Spring Keepers	316SS**
16	1	Bonnet Vent	DELTRIN
17	1	Sense Piston Seal	FKM**
18	1	Wire Seal	SA 108
19	1	Up. Outlet Nozzle Seal	FKM**
20	3	Hex HD Bolt 1-1/4L	316SS**
21	1	Hex HD Bolt (Wire) 1-1/4L	316SS**
22	3	Hex HD Bolt 2L	316SS**
23	1	Hex HD Bolt (Wire) 2L	316SS**
24	1	Piston Nut	18-8SS
25	3	Body Plugs	316SS**
26*	1	Street Elbow W/Mesh	316SS**
27	1	Bonnet	316SS**
28	2	Spring	INCONEL X-750
29	1	Adjustment Screw	18-8SS
30	1	Thread Protector	316SS**
31	1	Filter	316SS**
32	1	Spool	316SS**
33	1	Spool Sleeve	316SS**
34	1	Spool Nut	316SS**

*Item not shown

**Dependent on application

Inlet Flange Ratings

Maximum Pressure Rating, psig [barg]

Flange Class	Material	Maximum Pressure Rating, psig [barg]					Temp. °F [°C] 500 [260]
		-50 to -21 [-45 to -30]	-20 to 100 [-20 to 38]	200 [93]	300 [149]	400 [205]	
150#	CS ¹	—	285 [19.7]	260 [17.9]	230 [15.9]	200 [13.8]	170 [11.7]
	SS ²	275 [19.0]	275 [19.0]	240 [16.6]	215 [14.8]	195 [13.5]	170 [11.7]
300#	CS	—	740 [51.0]	675 [46.6]	655 [45.2]	635 [43.8]	600 [41.4]
	SS	720 [49.6]	720 [49.7]	620 [42.8]	560 [38.6]	515 [35.5]	480 [33.1]
600#	CS	—	1480 [102.1]	1350 [93.1]	1315 [90.7]	1270 [87.6]	1200 [82.8]
	SS	1440 [99.3]	1440 [99.3]	1240 [85.5]	1120 [77.2]	1030 [71.0]	955 [65.9]
900#	CS	—	2220 [153.1]	2025 [139.6]	1970 [135.8]	1900 [131.0]	1795 [123.8]
	SS	2160 [149.0]	2160 [149.0]	1860 [128.3]	1680 [115.8]	1540 [106.2]	1435 [99.0]
1500#	CS	—	3705 [255.5]	3375 [232.7]	3280 [226.2]	3170 [218.6]	2995 [206.6]
	SS	3600 [248.2]	3600 [248.2]	3095 [213.4]	2795 [192.7]	2570 [177.2]	2390 [164.8]
2500#	CS	—	6170 [425.4]	5625 [387.8]	5470 [377.2]	5280 [364.1]	4990 [344.1]
	SS	6000 [413.7]	6000 [413.7]	5160 [355.8]	4660 [321.3]	4280 [295.1]	3980 [274.5]

Notes

1. CS: A216, Grade WCC
2. SS: A351, Grade CF8M

Resilient Seal Rating

Material	Continuous Process Temperature, °F [°C]		Minimum Pressure, psig [barg]		Maximum Pressure, psig [barg]	
	Minimum	Maximum Pilot	Main	Pilot	Main	Pilot
BUNA-N	-50 [-45]	+275 [135]	15 [1.03]	15 [1.03]	1000 [69]	3705 [255]
Fluorocarbon	-20 [-29]	+400 [205]	15 [1.03]	15 [1.03]	1000 [69]	3705 [255]
Ethylene Propylene	-65 [-54]	+325 [163]	15 [1.03]	15 [1.03]	1000 [69]	3705 [255]
PTFE	-50 [-45]	+500 [205]	15 [1.03]*		1000 [69]	

* - For inlet sizes 4 in. and larger. 1000psig [69 barg] minimum for 3 in. inlet and smaller.

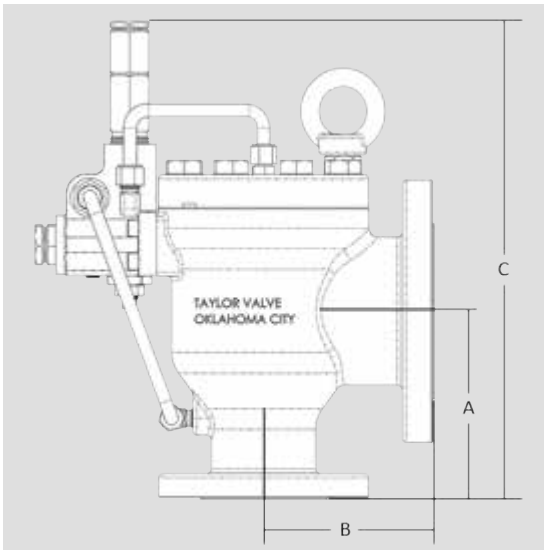

Orifice	Inlet x Outlet (Inches)	Available Flange Classes Inlet x Outlet	A	B	SNAP		MODULATOR	Approx. Weight (lbs)
					C		C	
					15-1480 psig	1481 psig+	15-3705 psig	
D, E, F	1 x 2	150 x 150	4-1/8	4-1/2	12-1/2	-	19-5/16	27
		300 x 150	4-3/8	4-1/2	12-1/2	-	19-5/16	28
		600 x 150	4-3/8	4-1/2	12-1/2	-	19-5/16	29
		900/1500 x 300	4-15/16	4-3/4	12-1/2	15-5/8	19-5/16	36
D, E, F	1-1/2 x 2	150 x 150	4-7/8	4-3/4	13	-	20-3/8	30
		300 x 150	4-7/8	4-3/4	13	-	20-3/8	33
		600 x 150	4-7/8	4-3/4	13	-	20-3/8	35
		900/1500 x 300	5-7/8	5-1/2	13	16-1/8	20-3/8	45
G, H	1-1/2 x 3	150 x 150	5-1/8	4-7/8	13-1/2	-	20-7/8	39
		300 x 150	5-1/8	4-7/8	13-1/2	-	20-7/8	43
		600 x 150	5-1/8	4-7/8	13-1/2	-	20-7/8	44
		900/1500 x 300	6-3/8	6-3/4	13-1/2	16-5/8	20-7/8	49
G, H, J	2 x 3	150 x 150	5-3/8	4-7/8	13-1/2	-	20-7/8	50
		300 x 150	5-3/8	4-7/8	13-1/2	-	20-7/8	52
		600 x 150	5-3/8	4-7/8	13-1/2	-	20-7/8	54
		900/1500 x 300	6-9/16	6-3/4	13-1/2	16-5/8	20-7/8	79
J, K, L	3 x 4	150 x 150	6-1/8	6-3/8	14-7/8	-	22-3/8	86
		300 x 150	6-1/8	6-3/8	14-7/8	-	22-3/8	92
		600 x 150	6-3/8	6-3/8	14-7/8	-	22-3/8	93
		900 x 300	7-1/2	7-1/8	14-7/8	18	22-3/8	123
L, M, N, P,	4 x 6	150 x 150	7-3/4	8-1/4	15-5/8	-	23-1/8	142
		300 x 150	7-3/4	8-1/4	15-5/8	-	23-1/8	149
		600 x 150	7-3/4	8-1/4	15-5/8	-	23-1/8	158
		900 x 300	9-13/16	9-3/16	15-5/8	18-7/8	23-1/8	229
Q, R	6 x 8	150 x 150	9-7/16	9-1/2	17	-	24-3/8	410
		300 x 150	9-7/16	9-1/2	17	-	24-3/8	425
		600 x 150	9-11/16	9-1/2	17	-	24-3/8	450
T	8 x 10	150 x 150	10-7/8	11	18-3/8	-	25-7/8	775
		300 x 150	10-7/8	11	18-3/8	-	25-7/8	800
		600 x 150	11-11/16	11	18-3/8	-	25-7/8	850

Orifice Dimensions and Weights

Orifice Sizes

API Letter	D	E	F	G	H	J	J	K
Inlet Size	1", 1 1/2"	1", 1 1/2"	1", 1 1/2"	1 1/2", 2"	1 1/2", 2"	2"	3"	3"
Outlet Size	2"	2"	2"	3"	3"	3"	4"	4"
Flow Area	0.128	0.212	0.357	0.472	0.913	1.431	1.431	2.138
Bore Diameter	0.404	0.52	0.674	0.775	1.078	1.35	1.35	1.65
Minimum Lift	0.202	0.26	0.337	0.388	0.539	0.675	0.675	0.825
Pressure Range	3705	3705	3705	3705	3705	2000	2000	2000
Rated Coefficient of Discharge (Kd)(Gas/Steam)	0.878	0.878	0.878	0.878	0.878	0.878	0.878	0.878
Rated Coefficient of Discharge (Kd)(Liquid)	0.829	0.829	0.829	0.829	0.829	0.829	0.829	0.829

Orifice Sizes

API Letter	L	L	M	N	P	Q	R	T
Inlet Size	3"	4"	4"	4"	4"	6"	6"	8"
Outlet Size	4"	6"	6"	6"	6"	8"	8"	10"
Flow Area	3.205	3.205	4.083	4.909	7.069	12.566	17.721	25.967
Bore Diameter	2.02	2.02	2.28	2.5	3	4	4.75	5.75
Minimum Lift	1.01	1.01	1.14	1.25	1.5	2	2.375	2.875
Pressure Range	2000	2000	2000	2000	1480	1480	1480	1480
Rated Coefficient of Discharge (Kd)(Gas/Steam)	0.878	0.878	0.878	0.878	0.878	0.878	0.878	0.878
Rated Coefficient of Discharge (Kd)(Liquid)	0.829	0.829	0.829	0.829	0.829	0.829	0.829	0.829

Full Bore

Full Bore Size	1-1/2"	2"	3"	4"	6"	8"
Inlet Size	1-1/2"	2"	3"	4"	6"	8"
Outlet Size	2"- 3"	3"	4"	6"	8"	10"
Flow Area	1.767	2.953	6.605	11.491	26.067	45.664
Bore Diameter	1.5	1.939	2.9	3.825	5.761	7.625
Minimum Lift	0.75	0.97	1.45	1.915	2.88	3.812
Pressure Range	2000	2000	1480	1480	1480	1480
Rated Coefficient of Discharge (Kd)(Gas)	0.774	0.774	0.774	0.774	0.774	0.774

Model Numbering System

A PILOT TYPE	
CODE	ORIFICE
S	SNAP
M	MODULATING
SS	STEAM SNAP

B ORIFICE	
CODE	CODE
D	M
E	N
F	P
G	Q
H	R
J	T
K	FB
L	

C INLET/OUTLET SIZE	
CODE	SIZE
1	1" X 2"
2	1-1/2" X 2"
3	1-1/2" X 3"
4	2" X 3"
5	3" X 4"
6	4" X 6"
7	6" X 8"
8	6" X 8" X 8"
9	8" X 10"
10	8" X 10" X 10"
41	2" X 4"

D SPRING RANGE			
SNAP		MODULATING	
CODE	RANGE	CODE	RANGE
00	15-24	00	15-23
01	25-34	01	24-30
02	35-52	02	41-70
03	53-80	03	71-160
04	81-130	04	161-300
05	131-182	05	301-550
06	183-275	06	551-1000
07	276-410	07	1001-1480
08	411-615	08	1481-3200
09	616-920	09	3201-3705
10	921-1150		
11	1151-1480		
12	1481-2160		
13	2161-3240		
14	3241-3705		

E INLET CLASS	
CODE	SIZE
1	150
2	300
3	600
4	900
5	1500
6	2500
7	FNPT

F OUTLET CLASS	
CODE	CLASS
1	150
2	300
3	600
4	FNPT

G FLANGE TYPE	
CODE	TYPE
0	RF X RF
1	RF X RTJ
2	RTJ X RF
3	RTJ X RTJ
X	OTHER

H MAIN BODY MATERIAL OPTIONS	
CODE	SIZE
1	CS BODY WITH 17-4 H1150 INTERNALS
2	SS BODY WITH 17-4 H1150 INTERNALS
3	CS BODY WITH 316 INTERNALS
4	SS BODY WITH 316 INTERNALS
X	OTHER

I MAIN BODY SEAT/O-RING	
CODE	TYPE
1	FKM/FKM
2	PTEE/FKM
3	PC BUNA/PC BUNA
4	EPDM/EPDM
6	FKM 95 DURO
7	AFLAS
8	PTFE/BUNA
9	PTFE/EPDM
D	PTFE/LoTemp NBR
E	PTFE/Kalrez O-Ring
X	Other

LM LIST OPTIONS	
CODE	
00	VENT TO ATMOSPHERE (STD. FOR AIR SERVICE)
01	COALESCING FILTER
02	MANUAL BLOWDOWN
03	REMOTE BLOWDOWN
04	LIFT LEVER
05	BACKFLOW PREVENTER (FULL BORE)
06	REMOTE VALVE LIFT INDICATOR
07	VENT TO MAIN BODY OUTLET (STD. FOR LIQUID SERVICE)
08	FILTER W/PILOT VENT CONNECTED TO MAIN VALVE OUTLET

J PILOT O-RING	
CODE	TYPE
1	FKM
3	PC BUNA
4	EPDM
7	LoTemp NBR

K SERVICES	
CODE	SIZE
0	STD
4	NACE
X	OTHER

If more than one option is requested see engineering

Example:

93M-D10211011110-08

- Modulating Pilot
 - D orifice
 - 1" X 2"
 - 41-70 PSI Set Pressure
 - 150 Class Inlet Flange
 - 150 Class Outlet Flange
 - Raised Face Flange X Raised Face Flange
 - Carbon Steel Body with 17-4 H-1150 Internals
 - FKM Seat/FKM O-Rings in Main Body
 - FKM O-Rings in Pilot
 - Standard Non-NACE Service
- With Options:
With coalescing filter and pilot vent to main valve outlet

93A-BCDEFGHIJK-LM

How to Size a Valve

Valves are selected on the basis of their ability to meet an expected relieving condition, flowing a sufficient amount of fluid to prevent excessive pressure increase. This means that the size of the valve orifice must be calculated taking the required flow, performance characteristics, lading fluid properties, and other factors into consideration.

The sizing procedure presented utilizes the recommended practice of API 520 Part 1. The valve orifice areas and nozzle discharge coefficients shown are effective values in that they are not specific to a particular valve type. The use of these effective orifice areas and effective nozzle discharge coefficients will always allow for the selection of a valve orifice area that will meet or exceed the required capacity. The calculation of the actual valve capacity required can be performed with the Taylor Valve Technology sizing software program. Contact sales for sizing discs.

To select the minimum required orifice area that will flow the required capacity of the system you wish to protect, please refer to the following information which appears in this section:

1. Sizing Formulas
2. Correction Factors
3. Valve Flow Coefficients

Sizing Formulas

To determine the relieving capacity which should appear on a valve for a given pressure, use either the Coefficient Method or Slope Method.

$$\text{For Gas/Vapor, lb/hr: } W = A C K_d P_1 \sqrt{\frac{M}{T}}$$

$$\text{For Gas/Vapor, SCFM: } V = 6.32 C K_d P_1 A \frac{1}{\sqrt{TMZ}}$$

$$\text{For Air (ASME Capacity), SCFM: } V = 18.331 \cdot K_d A P_1$$

$$\text{For Liquid, GPM: } Q = 38 \cdot A K_d K_v \sqrt{\frac{P_1 - P_2}{G}}$$

$$\text{For Water(ASME Capacity), GPM: } Q = 38 A K_d \sqrt{P_1 - P_2}$$

SLOPE METHOD

$$\text{For Air, SCFM: } V = \text{slope} \cdot P_1$$

$$\text{For Water, GPM: } Q = F \sqrt{P_1 - P_2}$$

Symbol Description		English Units	Metric Units
A	Calculated Orifice Area	in ²	mm ²
V	Required Capacity, Volume	SCFM	Nm ³ /min
G	Specific Gravity	–	–
M	Molecular Weight (M = 29 x Specific Gravity)	–	–
T	Relief Temperature (°R = °F + 460°; °K = °C + 273°)	°R	K
Z	Compressibility Factor (if unknown, assume Z = 1.0)	–	–
k	Ratio of Specific heats (k = $\frac{C_p}{C_v}$)	–	–
C	Gas Constant (if unknown, assume C = 315)	–	–
Kd	Effective Nozzle Coefficient for 90% of Actual Capacity	–	–
P	Set Pressure	psig	kPag
P1	Inlet Flowing Pressure (P1 = P + Allowable Overpressure - Inlet Pressure Loss + Atmospheric Pressure)	psia	kPaa
P2	Outlet Pressure (Back pressure)	psia	kPaa
Kb	Back pressure factor	–	–
W	Required Capacity, Mass	Lbs/Hr	Kg/Hr

Values of M, k and C for Representative Gases & Vapors

Gas or Vapor	M Molecular Weight	k Specific Heat Ratio	C Gas Constant
Acetylene (C ₂ H ₂)	26	1.26	343
Air	29	1.40	356
Ammonia (NH ₃)	17	1.31	348
Argon (Ar)	40	1.67	378
Benzene (C ₆ H ₆)	78	1.12	329
Butadiene (C ₄ H ₆)	54	1.12	329
Carbon Dioxide (CO ₂)	44	1.28	345
Carbon Monoxide (CO)	28	1.40	356
Ethane (C ₂ H ₆)	30	1.19	336
Ethylene (C ₂ H ₄)	28	1.24	341
Freon 22	86.5	1.18	335
Helium (He)	4	1.66	377
Hexane (C ₆ H ₁₄)	86	1.06	322
Hydrogen (H ₂)	2	1.41	357
Hydrogen Sulphide (H ₂ S)	34	1.32	349
Methane (CH ₄)	16	1.31	348
Methyl Mercaptan (CH ₄ S)	48.1	1.20	337
n-Butane (C ₄ H ₁₀)	58	1.09	326
Natural Gas (SF=0.60)	17.4	1.27	344
Nitrogen (N ₂)	28	1.40	356
Oxygen (O ₂)	32	1.40	356
Pentane (C ₅ H ₁₂)	72	1.97	323
Propane (C ₃ H ₈)	44	1.13	330
Propylene (C ₃ H ₆)	42	1.15	332
Propylene Oxide (C ₃ H ₆ O)	58.1	1.21	338
Steam	18	1.31	348
Sulphur Dioxide (SO ₂)	64	1.29	346
VCM (C ₃ H ₃ Cl)	62.5	1.18	335

Gas Constant, C

k	C
1.00	315
1.02	318
1.04	320
1.06	322
1.08	324
1.10	327
1.12	329
1.14	331
1.16	333
1.18	335
1.20	337
1.22	339
1.24	341
1.26	343
1.28	345
1.30	347
1.32	349
1.34	351
1.36	352
1.38	354
1.40	356
1.42	358
1.44	359
1.46	361
1.48	363
1.50	364

Gas Constant, C

k	C
1.52	366
1.54	368
1.56	369
1.58	371
1.60	372
1.62	374
1.64	376
1.64	376
1.68	379
1.70	380
1.72	382
1.74	383
1.76	384
1.78	386
1.80	387
1.82	388
1.84	390
1.86	391
1.88	392
1.90	394
1.92	395
1.94	397
1.96	398
1.98	399
2.00	400
2.02	401

K_b = Back pressure correction factor
 k = Ratio of Specific heats

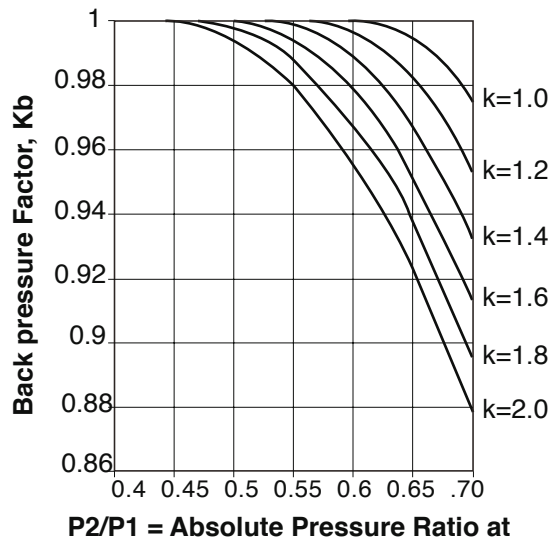



Taylor Valve Technology
8300 S.W. 8th Street
Oklahoma City, Oklahoma 73128

TEL 405.787.0145
FAX 800.805.3401
WEB www.taylorvalve.com
EMAIL info@taylorvalve.com



Unique.

Precise.

Quality.

Reliable.

